

# CLARKE<sup>®</sup>

## air



## AIR HAMMER

MODEL NO: CAT114

PART NO: 3110870

## OPERATING & MAINTENANCE INSTRUCTIONS

UK  
CA | CE

ORIGINAL INSTRUCTIONS

DL1122 - Rev 2

---

## INTRODUCTION

---

Thank you for purchasing this CLARKE Air Hammer. Before attempting to use this product, please read this manual thoroughly and follow the instructions carefully. In doing so you will ensure the safety of yourself and that of others around you, and you can look forward to your purchase giving you long and satisfactory service.

**Keep these instructions in a safe place for future reference.**

---

## SPECIFICATIONS

---

Maximum Operating Pressure	90 psi (6.2 bar)
Air Consumption (under load)	3-16 cfm (84-452 l/min)
Max Blows per minute	4500
Air Inlet Size	1/4" BSP female thread
Vibration Levels	14.6 m/s <sup>2</sup> (uncertainty factor K= 0.99m/s <sup>2</sup> )
Sound pressure level	84 dB LpA
Sound power level	95 dB LWA
Dimensions (L x W x H)	153 x 48 x 152 mm
Weight	1.3 kg

Please note that the details and specifications contained herein are correct at the time of going to print. However CLARKE International reserve the right to change specifications at any time without prior notice.

---

# GENERAL SAFETY RULES

---



CAUTION: FAILURE TO FOLLOW THESE PRECAUTIONS COULD RESULT IN PERSONAL INJURY, AND/OR DAMAGE TO PROPERTY.

---

## THE WORK ENVIRONMENT

1. ALWAYS keep the work area clean and tidy.
2. ALWAYS dress appropriately - Do not wear loose clothing or jewellery. Tie long hair out of the way.
3. ALWAYS keep children and visitors away - Do not let children handle the air tool.

## USE OF AIR POWERED TOOLS

1. ALWAYS stay alert and use common sense - do not operate this air tool when you are tired or under the influence of alcohol, drugs or medication.
2. ALWAYS wear eye protectors when using air tools. Eye protectors must provide protection from flying particles from the front and the side.
3. ALWAYS wear ear protectors and a dust mask when using an air hammer.
4. DO NOT overreach - keep proper footing and balance at all times.
5. DO NOT fit the air tool to a stand or clamping device that may damage it.
6. NEVER use oxygen, CO<sup>2</sup>, combustible gases, or any bottled gas, as a source of power for the grease gun. This product should only be used with a suitably rated compressed air supply.
7. DO NOT connect the air hose with your finger on the trigger of the air tool.
8. ALWAYS keep the air supply hose away from heat, oil and sharp edges.
9. DO NOT exceed the maximum pressure for the tool of 90 psi / 6.2 bar.
10. ALWAYS check hoses for leaks or excessive wear before use and ensure that all connections are secure.
11. DO NOT use the tool for any other purpose than described in this manual.
12. DO NOT carry out any alterations or modifications to the air tool.
13. ALWAYS disconnect from the air supply when:
  - Performing any maintenance.
  - The tool is not in use.

- The tool will be left unattended.
- Moving to another work area.

14. Avoid damaging the tool by applying excessive force of any kind.
15. ALWAYS maintain the tool with care. Keep it clean for the best and safest performance.
16. DO NOT force or misuse the tool. It will do a better and safer job at the rate for which it was designed.
17. This tool vibrates with use. Vibration may be harmful to your hands or arms. Stop using the tool if discomfort, a tingling feeling or pain occurs. Seek medical advice before resuming use.
18. DO NOT carry an air tool by the air supply hose.
19. DO NOT carry an air tool with your finger on the trigger.

### **AIR HAMMER SPECIFIC HAZARDS**

1. Only use accessories designed for use with this air tool.
2. DO NOT use any of the chisels supplied as hand struck tool.
3. DO NOT use blunt chisels which require excessive pressure and can break from fatigue. Always use sharp tools.
4. NEVER mis-use the tool by prising which can result in a broken tool.
5. ALWAYS ensure there are no hidden electrical cables, gas pipes etc, which could cause a hazard if damaged by action of the chisels.

# COMPRESSED AIR REQUIREMENTS



**WARNING: COMPRESSED AIR CAN BE DANGEROUS. ENSURE THAT YOU ARE FAMILIAR WITH ALL PRECAUTIONS RELATING TO THE USE OF COMPRESSORS AND A COMPRESSED AIR SUPPLY.**

A typical air line layout is shown below. If an automatic in-line filter/regulator is used, it will keep the tool in good condition, but should be regularly checked & topped up with oil. CLARKE air-line oil should be used, and the lubricator adjusted to approx 2 drops per minute.

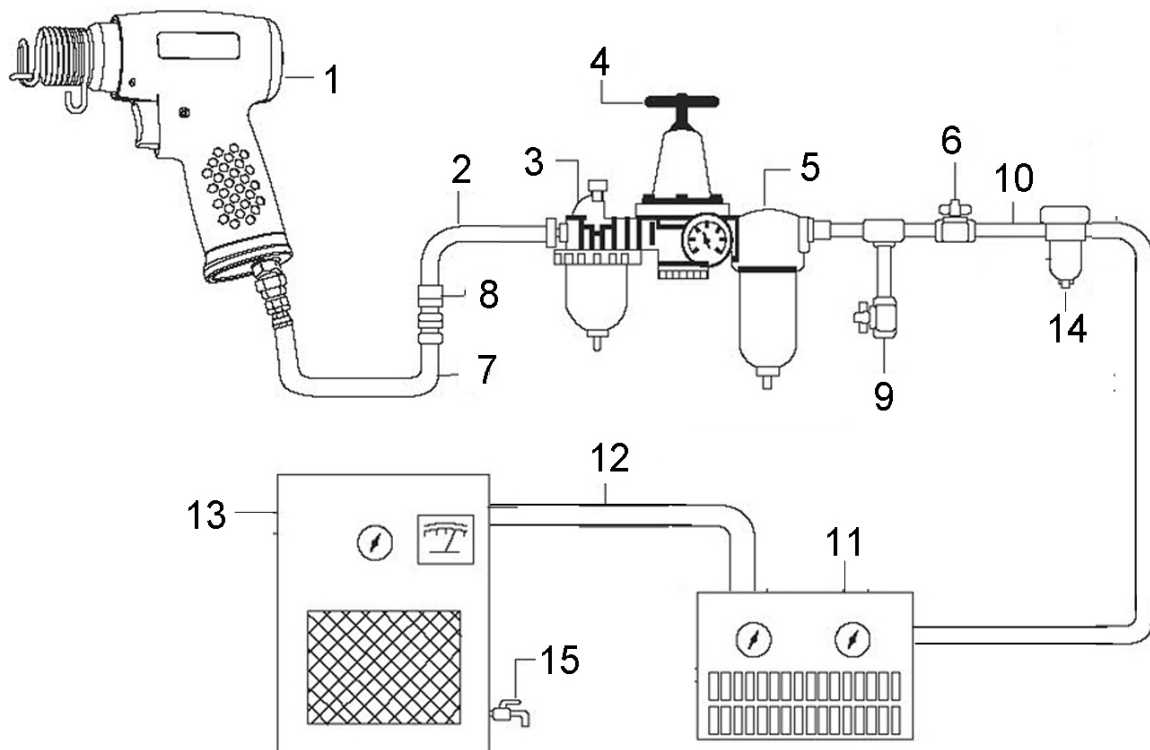

## AIR SYSTEM LAYOUT :

- |                               |                                     |
|-------------------------------|-------------------------------------|
| 1. Air Tool                   | 9. Drain Valve                      |
| 2. Air Hose 3/8" (I.D.)       | 10. 1/2" Or Larger Pipe And Fitting |
| 3. Oiler                      | 11. Air Dryer                       |
| 4. Pressure Regulator         | 12. 1" Or Larger Pipe And Fitting   |
| 5. Filter                     | 13. Air Compressor                  |
| 6. Shut Off Valve             | 14. Auto Drain                      |
| 7. Whip Hose                  | 15. Drain Valve                     |
| 8. Coupler Body And Connector |                                     |

Use only clean, dry, regulated compressed air as a power source.

Air compressors used with the air tool must comply with the appropriate European Community Safety Directives.

A build-up of moisture or oil in the air compressor will accelerate wear and corrosion in the tool. ensure any moisture is drained from the compressor daily and the inlet filter is kept clean.

If an unusually long air hose is required, (over 8 metres), the line pressure or the hose inside diameter may need to be increased.

The air hose must be rated at least 150% of the maximum operating pressure of the air tool.

DO NOT exceed the maximum operating pressure for the air tool. It is recommended that air pressure to this tool does not exceed 90 psi at the tool when running. Higher pressures and unclean air will shorten the life of an air tool due to faster wear and is a possible safety hazard.

# OVERVIEW

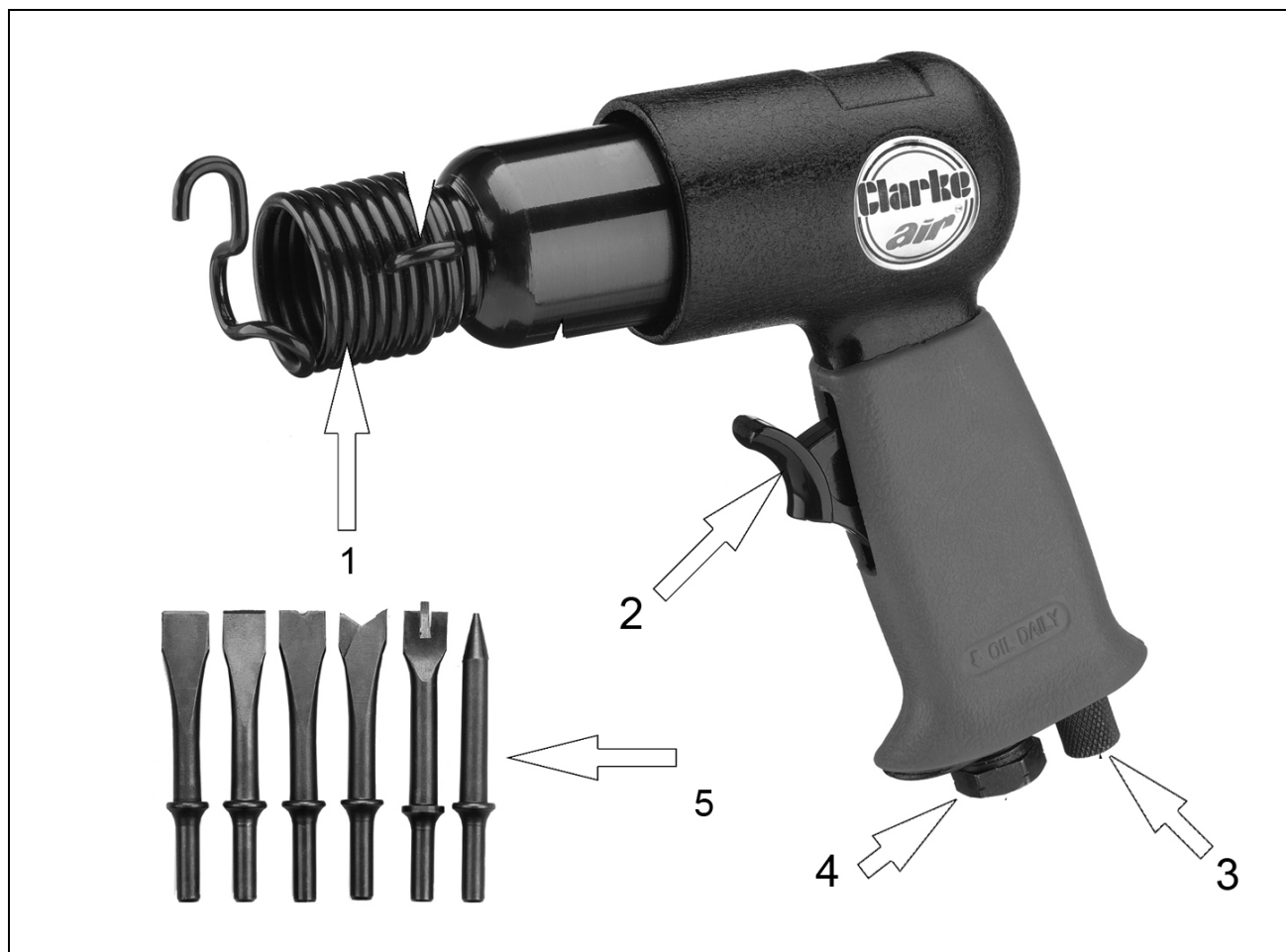

1	Retaining spring
2	Trigger
3	Speed controller
4	Inlet adaptor
5	Chisel Set including: A - Piercing cutter B - Spot weld chisel C - Rivet cutter D - Bush splitter E - Panel cutter

---

## BEFORE USE

---



**WARNING: COMPRESSED AIR CAN BE DANGEROUS. ENSURE THAT YOU ARE FAMILIAR WITH ALL PRECAUTIONS RELATING TO THE USE OF AIR COMPRESSORS AND A COMPRESSED AIR SUPPLY.**

---

### CONNECTING THE AIRLINE

1. Remove the travel plug.
2. Pour 2-3 drops of CLARKE airline oil into the oil filling port. This should be done regardless of whether or not a lubricated air supply is used.
3. If required, connect an in-line mini oiler to the tool. Read the instructions supplied with the mini-oiler before use.

- A mini oiler helps to prolong the life of any air tool.

4. Connect a suitable hose. This can be done using either the male adaptor supplied or using a mini oiler from your CLARKE dealer.
5. Connect the other end of the hose to the compressor.

- PTFE tape may be useful for sealing threaded connections.

6. Turn on the air supply and check for air leaks. Rectify any found before proceeding. Set the working pressure to 90psi (6.2 bar) for best performance
7. Place a sheet of paper next the exhaust port and squeeze the trigger for approximately 30 seconds. The oil volume is correctly set when a light stain of oil can be seen on the paper. Excessive oil should be avoided.

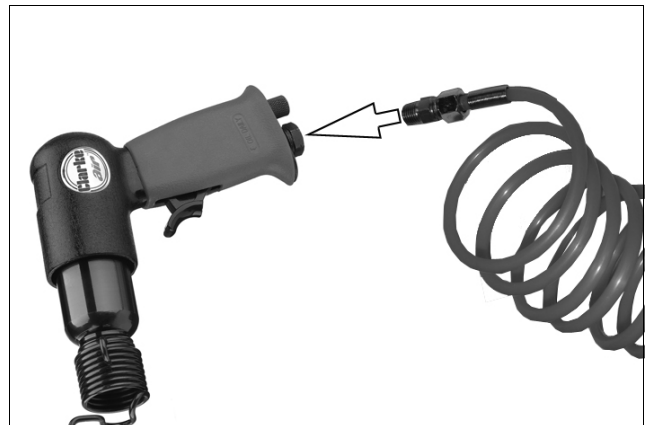
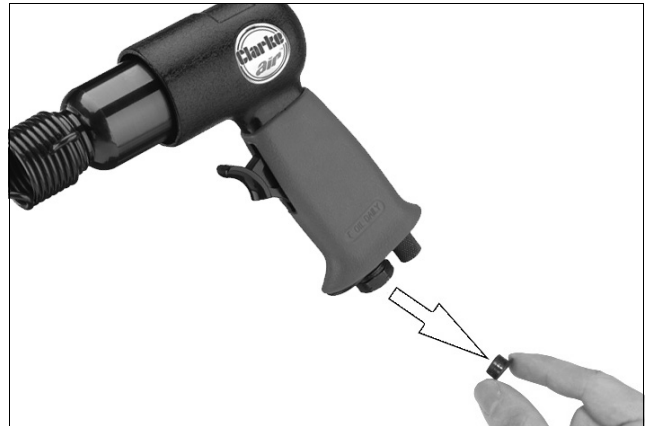



# OPERATION

## FITTING THE CHISEL

1. Select which chisel is best suited to the task. A selection of chisels is supplied as shown.

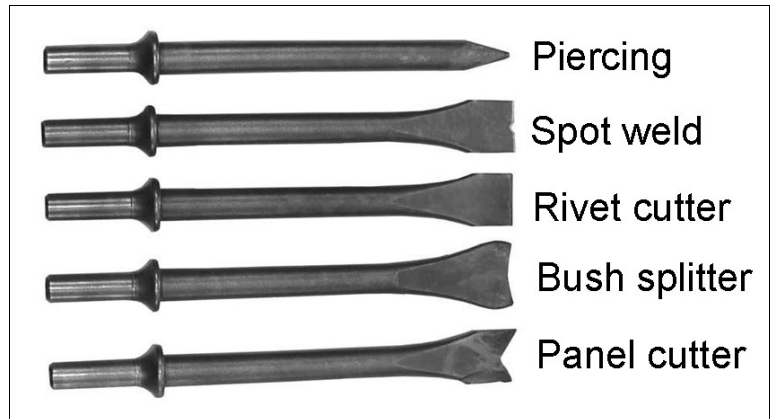

2. First remove the retaining spring from the nose by unscrewing it.
  - Use the inboard lug to gain purchase.
3. Insert the chisel into the air hammer as shown.
4. Replace the retaining spring.
  - Use the lugs to help tighten.

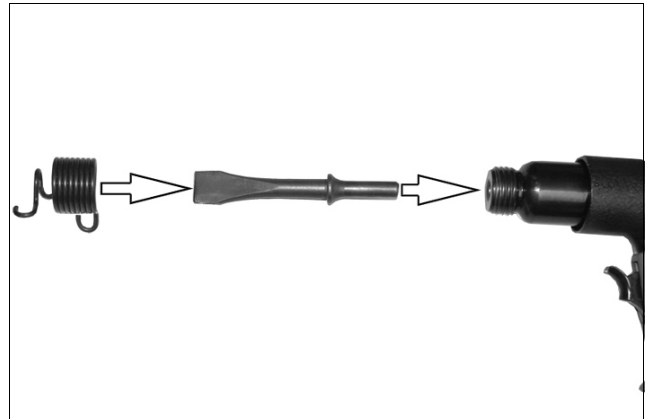

## ADJUSTING THE FORCE

Chisel force may be adjusted by turning the speed controller/air regulator knob, located at the base of the handle.

- Turn anticlockwise to increase force.
- Turn clockwise to reduce the force.

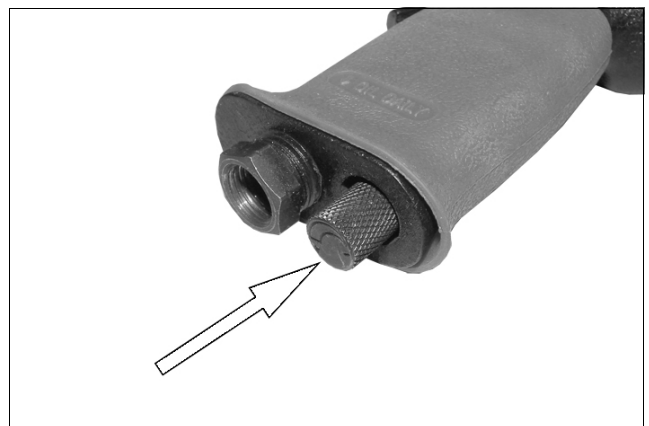

## USING THE AIR HAMMER

1. Hold the tool firmly with one hand around the handle and one hand around the barrel, then bring the tool towards the work at an angle of approximately 60-70 degrees.
2. Squeeze the trigger with the chisel in light contact with the work.
  - The chisel speed is controlled by squeezing the trigger.

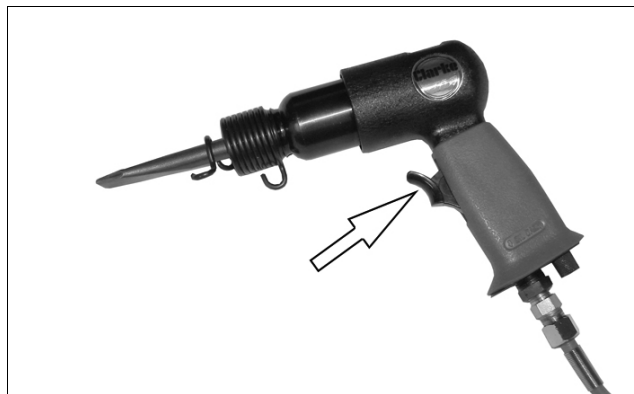

3. Move slowly across the work surface. To remove scale, rust or other contaminants, only a light force should be required.
4. Release the trigger to stop operation whilst maintaining contact with the work.

**NOTE:** The air tool may operate briefly after the trigger is released.

**NOTE:** The retaining spring has a life expectancy, depending upon the intensity of usage. It is recommended that you procure a spare spring for use in the event of failure occurring during the course of a particular job.

## DISCONNECTING THE AIR SUPPLY

1. Do not disconnect the air hose until the supply is isolated at a shut-off valve.
2. Once the pressure has been isolated, disconnect the air supply hose from the air tool.
3. Shut down the compressor at the end of the work session.

---

# MAINTENANCE

---



**WARNING: MAKE SURE THAT THE AIR TOOL IS DISCONNECTED FROM THE COMPRESSED AIR SUPPLY BEFORE STARTING ANY CLEANING OR MAINTENANCE PROCEDURES.**

---

## DAILY

1. Before use, drain water from the compressed air supply.
2. If no line lubricator or mini oiler is used, ensure that oil is applied to the tool on a daily basis through the air inlet connection. Run a few drops of oil through the tool before use. It may be entered into the tool air inlet, (ensuring the strainer is clear), or into the hose at the nearest connection to the air supply. Then operate the tool.
3. This procedure should be repeated after every two to three hours of use, or at the start of the working day.
4. Keep the body of the tool clean and free from debris.

## CLEANING

1. Grit or gum deposits in the tool may reduce efficiency.
2. After extensive use, remove the inlet screen filter and flush out the mechanism with gum solvent oil or an equal mixture of CLARKE air-line oil and paraffin. Allow to dry before use.
3. If the tool still runs erratically or becomes inefficient, and the air supply is of good quality, it may be necessary to dismantle the air motor and replace worn or damaged parts. You may prefer to take the tool to your CLARKE dealer if internal maintenance is required.

## PERFORMANCE

Please note that outside factors may affect the operation and efficiency of the air tool, such as reduced compressor output, excessive drain on the airline, moisture or restrictions in the air-line, or the use of connectors of improper size or poor condition which will reduce air supply.

Your air tool has been designed to give long and trouble free service. If, however, having followed the instructions in this booklet carefully, you encounter problems, take the unit to your local CLARKE dealer.

## TROUBLESHOOTING

SYMPTOM	PROBLEM	SOLUTION
Tool runs at normal speed but slows down under any load.	<ol style="list-style-type: none"> <li>1. Motor parts worn.</li> <li>2. Worn or sticking mechanism due to lack of lubricant.</li> </ol>	<ol style="list-style-type: none"> <li>1. Return to CLARKE dealer for repair.</li> <li>2. Drip air tool lubricating oil into air inlet. Allow oil to soak moving parts before using.</li> </ol>
Tool runs slowly. Air flows weakly from exhaust.	<ol style="list-style-type: none"> <li>1. Motor parts jammed with gum/dirt.</li> <li>2. Air-line regulator in closed position.</li> <li>3. General airflow blocked by dirt.</li> </ol>	<ol style="list-style-type: none"> <li>1. Examine inlet air filter for blockage and clean if necessary. Drip a few drops of air tool lubricating oil into air inlet.</li> <li>2. Adjust in-line regulator to open position.</li> <li>3. Operate tool in short bursts.</li> </ol>
Tool will not run. Air flows freely from exhaust.	<ol style="list-style-type: none"> <li>1. Motor vanes stuck due to buildup of foreign material.</li> </ol>	<ol style="list-style-type: none"> <li>1. Disconnect air supply and rotate tool assembly manually.</li> <li>2. Try operating tool in short bursts.</li> <li>3. Tap motor housing gently with a rubber mallet.</li> <li>4. Drip a few drops of air tool lubricating oil into air inlet to soak moving parts.</li> </ol>
Tool will not shut off.	<ol style="list-style-type: none"> <li>1. O-rings damaged or ill-fitting in seat.</li> </ol>	<ol style="list-style-type: none"> <li>1. Return to CLARKE dealer for repair.</li> </ol>

## STORAGE

When not in use, disconnect from the air supply, clean & store in a safe, dry place. If the tool is to be stored, or is idle for longer than 24 hours, run a few drops of CLARKE air line oil into the air inlet, and run the tool for 5 seconds in order to lubricate the internal parts.

When storing, replace the blanking plug on the airline inlet once the airline has been disconnected.

## **ACCESSORIES**

A wide range of accessories are available including filter/regulators, lubricators, high-pressure hoses (5 to 50 metres) etc.

Contact your CLARKE dealer or the CLARKE International Service Department for further information.

CLARKE Air Line Oil (part no. 3050825) is available from your CLARKE dealer.

---

## **GUARANTEE**

---

This product is guaranteed against faulty manufacture for a period of 12 months from the date of purchase. Please keep your receipt which will be required as proof of purchase.

This guarantee is invalid if the product is found to have been abused or tampered with in any way, or not used for the purpose for which it was intended.

Faulty goods should be returned to their place of purchase, no product can be returned to us without prior permission.

This guarantee does not effect your statutory rights.

# PARTS LIST & DIAGRAM

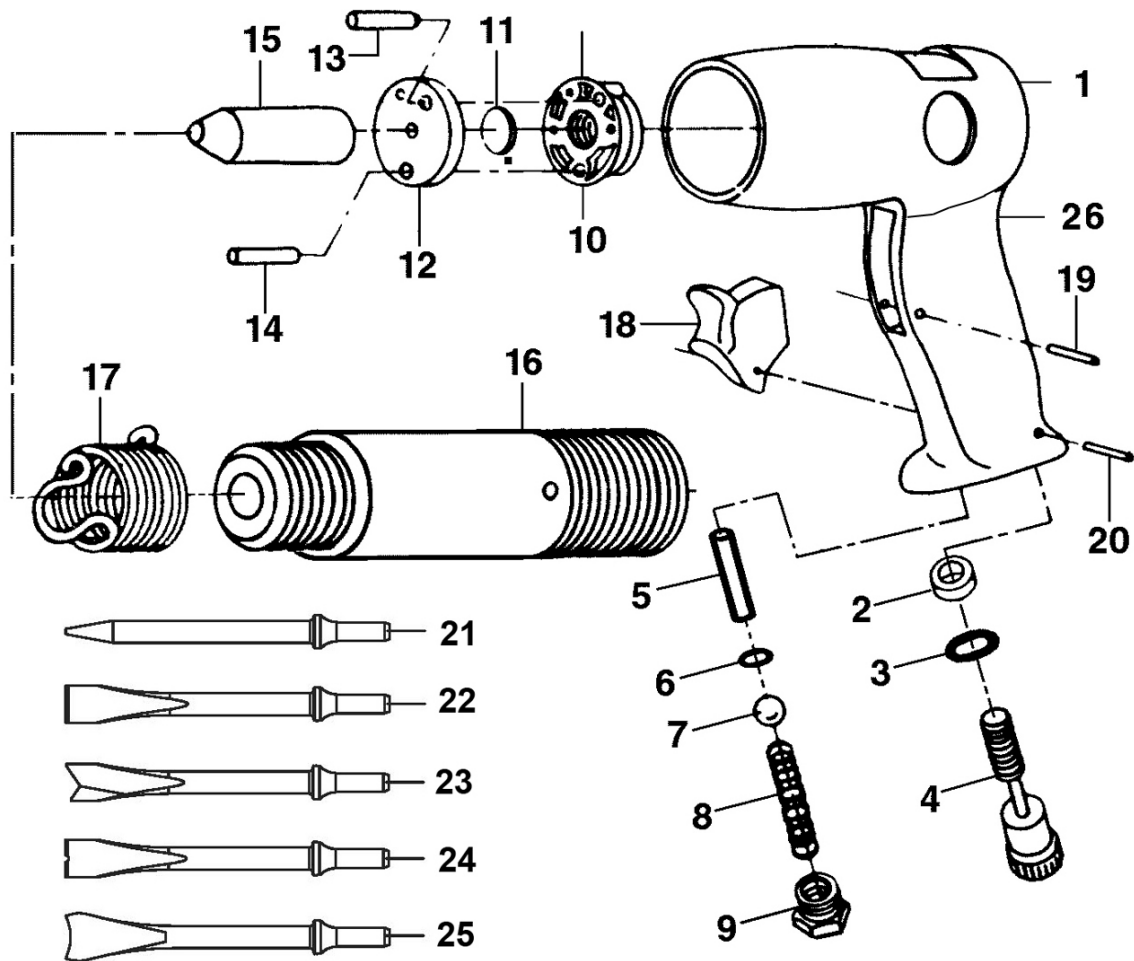

No	Description
1	Housing
2	Rubber Gasket
3	O-Ring
4	Regulator
5	Control Pin
6	O-Ring
7	Ball Valve
8	Spring
9	Air Inlet Connector
10	Rear Valve
11	Valve Disc
12	Front Valve
13	Pin

No	Description
14	Pin
15	Piston
16	Cylinder
17	Retainer Spring
18	Trigger
19	Roll Pin
20	Roll Pin
21	Piercing chisel
22	Rivet cutting chisel
23	Panel cutting chisel
24	Spot weld chisel
25	Bush splitting chisel
26	Sleeve grip

# DECLARATION OF CONFORMITY



Hennell Street, Epping, Essex CM16 4LG

## DECLARATION OF CONFORMITY

This is an important document and should be retained.

We hereby declare that this product(s) complies with the following statutory requirement(s):  
*Supply of Machinery (Safety) Regulations 2008*

The following standards have been applied to the product(s):

EN ISO 11148-4:2012.

The technical documentation required to demonstrate that the product(s) meet(s) the requirement(s) of the aforementioned legislation has been compiled and is available for inspection by the relevant enforcement authorities.

The UKCA mark was first applied in: 2022

Product Description: Air Hammer with Chisel Set  
Model number(s): CATT14  
Serial / batch Number: N/A  
Date of Issue: 06/10/2022

Signed:

  
J.A. Clarke  
Director



Fitzwilliam Hall, Fitzwilliam Place, Dublin 2

## DECLARATION OF CONFORMITY

This is an important document and should be retained.

We hereby declare that this product(s) complies with the following directive(s):  
*2006/42/EC Machinery Directive*

The following standards have been applied to the product(s):

EN ISO 11148-4:2012.

The technical documentation required to demonstrate that the product(s) meet(s) the requirement(s) of the aforementioned directive(s) has been compiled and is available for inspection by the relevant enforcement authorities.

The CE mark was first applied in: 2005

Product Description: Air Hammer with Chisel Set  
Model number(s): CATT14  
Serial / batch Number: N/A  
Date of Issue: 06/10/2022

Signed:

  
J.A. Clarke  
Director

**A SELECTION FROM THE VAST RANGE OF**

**Clarke®**

**QUALITY PRODUCTS**



**AIR COMPRESSORS**  
From DIY to industrial, Plus air tools, spray guns and accessories.

**GENERATORS**  
Prime duty or emergency standby for business, home and leisure.

**POWER WASHERS**  
Hot and cold, electric and engine driven - we have what you need

**WELDERS**  
Mig, Arc, Tig and Spot. From DIY to auto/industrial.

**METALWORKING**  
Drills, grinders and saws for DIY and professional use.

**WOODWORKING**  
Saws, sanders, lathes, mortisers and dust extraction.

**HYDRAULICS**  
Cranes, body repair kits, transmission jacks for all types of workshop use.

**WATER PUMPS**  
Submersible, electric and engine driven for DIY, agriculture and industry.

**POWERTOOLS**  
Angle grinders, cordless drill sets, saws and sanders.

**STARTERS/CHARGERS**  
All sizes for car and commercial use.



**PARTS & SERVICE:**

**0208 988 7400**

**Parts Enquiries**

**Parts@clarkeinternational.com**

**Servicing & Technical Enquiries**

**Service@clarkeinternational.com**

**SALES: UK 01992 565333 or Export 00 44 (0)1992 565335**

**Clarke® INTERNATIONAL** Hemnall Street, Epping, Essex CM16 4LG  
[www.clarkeinternational.com](http://www.clarkeinternational.com)